

FAST™

OPTIC RISER



CONTENTS



PRODUCT OVERVIEW

The FAST™ Optic Riser creates a 2.26" optical center line from the rail when paired with a lower 1/3 co-witness rail mounted sight. It comes standard with a two cross bolt rail clamp or can be retrofitted with the FAST™ QD Lever and works with all FAST™ FTC magnifier mounts.

One (1) FAST™ Optic Riser

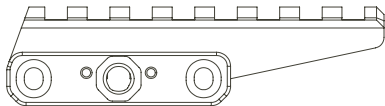

Two (2) Clamp Screws

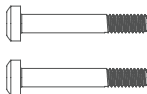

Two (2) Washers



One (1) Rail Clamp





WARNING: ENSURE FIREARM IS UNLOADED



CAUTION:

OVER-TORQUING FASTENERS CAN DAMAGE YOUR MOUNT AND WILL NOT BE COVERED BY WARRANTY. USING THREAD LOCKING COMPOUNDS, SUCH AS LOCTITE® OR OTHERS, IS NOT RECOMMENDED AND WILL VOID YOUR WARRANTY.



NOTE

Your lower 1/3 co-witness height optic of choice should be mounted to the FAST™ Optic Riser using the hardware provided with your optic. This can be done either before or after attaching your FAST™ Optic Riser on your M1913 rail at your preference.

2

Insert each Clamp Screw through a Washer. Then insert them through the FAST™ Optic Riser and thread them into the Rail Clamp. Secure screws using a T25 bit driver. Lightly snug all screws before applying final torque to any.
Torque to 35 in-lbs (4 Nm).

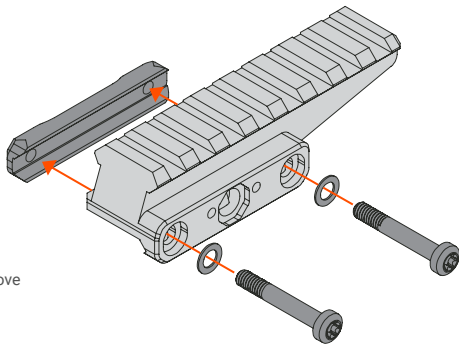

1

Place the FAST™ Optic Riser on the M1913 Rail in desired location. If using the included Rail Clamp, move to step 2. If using the optional FAST™ QD Lever (sold separately), jump to step 3.

3

Optional FAST™ QD (Quick Detach) Lever (sold separately) can be installed in place of the Rail Clamp. Installation instructions are included with the lever.

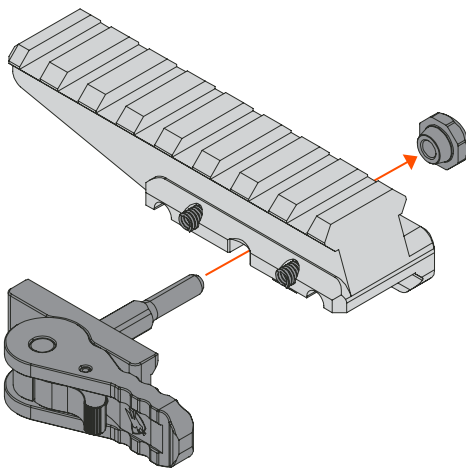

INFO@UNITYTACTICAL.COM

©2023 UNITY Tactical. All Rights Reserved.
Specifications subject to change without notice. PAT: UTIP,CO

