

FAST™

MICRO-S



CONTENTS



PRODUCT OVERVIEW

The FAST™ Micro-S is specifically designed for the Aimpoint® CompM5s, CompM5b and Duty RDS mini red dot sights. It puts these taller "micro" sights at the established FAST™ height of 2.26" and is fully compatible with the entire line of FAST™ FTC magnifier mounts. It comes standard with a 2 cross bolt rail clamp, but is compatible with the FAST™ QD (Quick Detach) Lever.

One (1) FAST™ Micro-S

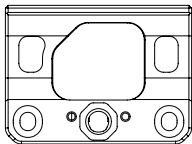

One (1) Rail Clamp



Two (2) Washers



Two (2) Clamp Screws



One (1) T10 Torx Key



Four (4) Optic Mounting Screws





WARNING: ENSURE FIREARM IS UNLOADED



CAUTION:

OVER-TORQUING FASTENERS CAN DAMAGE YOUR MOUNT AND/OR YOUR OPTIC AND WILL VOID YOUR WARRANTY. USING THREAD LOCKING COMPOUNDS, SUCH AS LOCTITE® OR OTHERS, IS NOT RECOMMENDED AND WILL VOID YOUR WARRANTY.

1

Using the UNITY™ supplied Optic Mounting Screws, install the optic to the mount. Tighten the screws in an "X" pattern until they are finger tight. Give each screw a 1/8 - 1/4 turn with the supplied torx key. **Do not exceed manufacturer's recommended torque spec.**

2

Place the FAST™ Micro-S mount on the M1913 Rail in desired location. If using the included Rail Clamp, move to step 3. If using the optional FAST™ QD Lever (sold separately), jump to step 4.

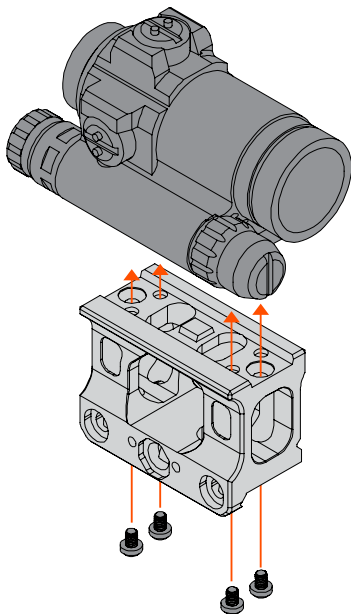

3

Insert each Clamp Screw through a Washer. Then insert them through the FAST™ Micro-S mount and thread them into the Rail Clamp. Secure screws using a T25 bit driver. Lightly snug all screws before applying final torque to any. **Torque to 35 in-lbs (4 Nm).**

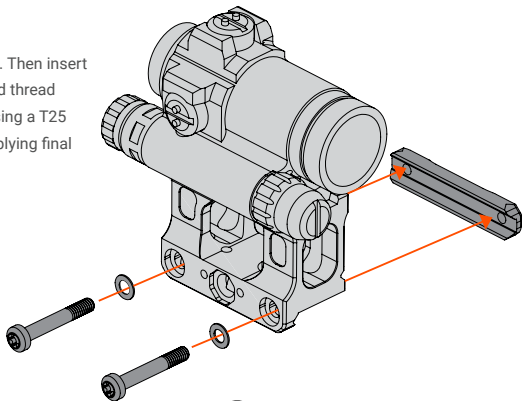

4

Optional FAST™ QD (Quick Detach) Lever (sold separately) can be installed in place of the Rail Clamp. Installation instructions are included with the lever.

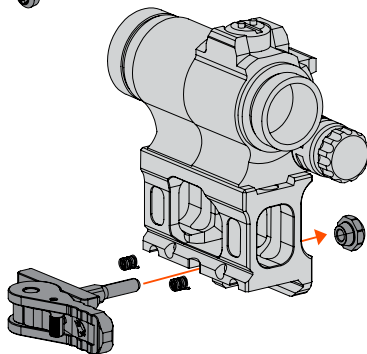

INFO@UNITYTACTICAL.COM

©2023 UNITY Tactical. All Rights Reserved.
Specifications subject to change without notice. PAT: UTIP.CO

