

# FAST™

FTC OMNI

LEGACY  
QD LEVER



USER

INSTRUCTIONS



The FAST™ FTC OMNI magnifier mount positions a variety of magnifiers from various manufacturers at a 2.26" optical centerline from the rail. It employs a simple force-to-overcome mechanism, stowing the magnifier below the optical sight plane and completely within the footprint of the weapon's receiver when not in use.

One (1) FAST™ FTC OMNI

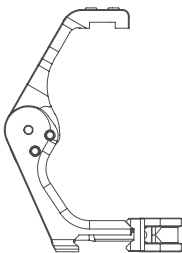

Two (2) 10-32 x 3/8" Magnifier Mounting Screws for EDTECH®, Trijicon® or Vortex®



One (1) Sig Sauer® JULIET Adapter



Two (2) M4 x 10mm Magnifier Mounting Screws for Holosun®



Four (4) M3 x 8.5mm Magnifier Mounting Screws for Sig Sauer®



**WARNING:****ENSURE FIREARM IS UNLOADED****CAUTION:**

Over-torquing fasteners can damage your mount and/or your optic and will void your warranty. Using thread locking compounds, such as Loctite® or others, is not recommended and will void your warranty.

**1**

Up-end and seat Magnifier in FAST™ mount arm (do not use shims from OEM magnifier kits). Insert the included two 10-32 x 3/8" Magnifier Mounting Screws in EOTECH®, Trijicon® or Vortex® optics. Insert the included two M4 x 10mm Magnifier Mounting Screws in Holosun™ optics. Insert the included four M3 x 8.5mm Magnifier Mounting Screws and the JULIET Adapter in Sig Sauer® optics. Secure EOTECH®, Trijicon® and Vortex® screws using a T20 bit driver. Secure Holosun™ and Sig Sauer® screws using a T10 bit driver. Lightly snug all screws before applying final torque to any.

**Torque all mounting screws to the specifications recommended by the manufacturer of your magnifier.**

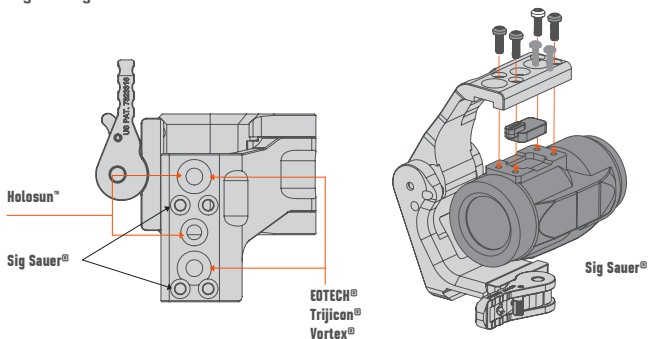



2

The FAST™ FTC OMNI mount uses a force-to-overcome mechanism. Grasp the magnifier body and pivot assembly down to the stowed position. Repeat in reverse to bring the magnifier back into the active position.

**NOTE:**

Do not adjust the Pivot Bolt or disassemble the mount. Doing so will void the warranty.

